

LED Indicator with Emergency Lighting Function

Kao-Feng Yarn¹, Wen-Bin Lin²

¹Department of Aircraft Maintenance, ²Department of Electronic and Optoelectronic Application Engineering, Far East University, Taiwan 744, ROC

Corresponding Author: Wen-Bin Lin

DOI: <https://doi.org/10.52403/ijrr.20220537>

ABSTRACT

This entity is a combination of LED indicators and emergency lighting equipment. In the current, security-conscious society, LED indicator lights are usually placed between corridors and emergency lighting is placed between staircases in enterprises or schools. Separate placement of the two will take up space, so this paper will combine the two to enhance their functions and design them as commercialized products. In addition to the practical concept, the appearance is also designed into a more beautiful modeling lamp.

Keywords: Emergency Lighting, LED, Indicator light

1. INTRODUCTION

The integration of "LED indicator" and "emergency lighting" into a system idea to save space and energy and to demonstrate its convenience and practicality. Most of the indicators on the market in general are fluorescent lamps, although in recent years most of the fluorescent lamps have been replaced by LED lamps in order to save electricity and energy, but there is no emergency lighting integration of the LED indicators. Therefore, we will not only combine the two into one, but also improve the LED part. The purpose is to save power on the one hand, and to reduce weight and space on the other [1-4].

2. SYSTEM STRUCTURE

The system structure block diagram is shown in Figure 1. To ensure the reliability of the application, the MBI1802 has a built-in temperature sensor with TP (Thermal Protection) and a heat sink.

A temperature sensor that detects the temperature status of the MBI1802. When the temperature of MBI1802 exceeds 165°C in the control circuit and LED driver IC, the overheat protection function turns off the current to prevent the driver from getting too hot. The MBI1802 has a tiny SOP8 package with a heat sink that transmits heat to the printed circuit board through a metal spacer to increase heat dissipation for safe handling of high output currents.

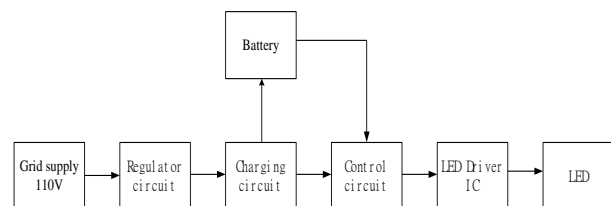

Figure 1: System structure block diagram

3. INTRODUCTION OF HARDWARE

3.1 MBI1802 LED Driver IC

Driver IC for immediate switching, designed for high power LEDs. Two channels of constant current output and high output current are provided; IC current can be set via an external resistor (R_{ext}) with a maximum output current of 360m amps. The IC has built-in temperature sensor and overheat protection. The temperature sensor detects the temperature status of the IC; when the temperature exceeds 165°C, the overheat protection function turns off the current to prevent the driver from overheating [4].

The LED driver IC used in this experiment is MBI8012, which uses its characteristics to control LEDs. This model is a constant current type to increase the life of LEDs usually used for high brightness lighting LEDs. The MBI1802 also provides a fast current adjustment mechanism that allows the output current to be adjusted downward to 25%

of the original set value. The MBI1802 can drive different LED lighting products, such as LED desk lamps, flashlights and MR16 bulbs. Based on the above advantages, we selected MBI1802 as the experimental LED driver IC. The function diagram is shown in Figure 2. Typical application circuit is shown in Figure 3. Pin Description is shown in Table 1.

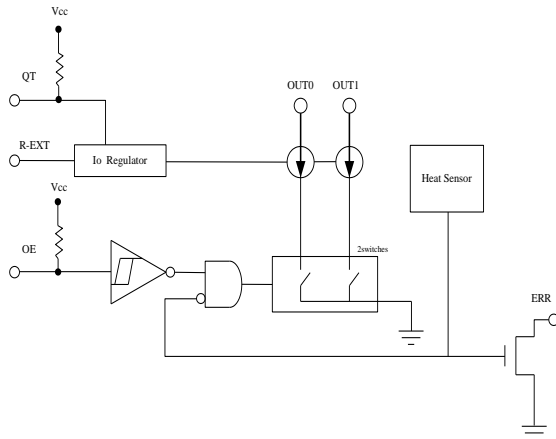

Figure 2: MBI1802 Function Diagram

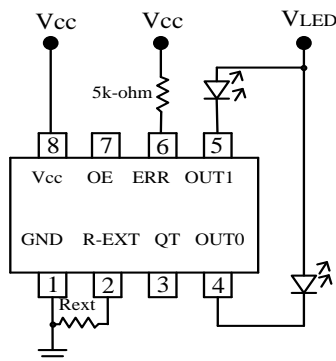

Figure 3: MBI1802 Typical Application Circuit

3.2 Eagle-Eye LED

The four-pin design of Eagle-Eye LEDs compared to the two-pin traditional light-emitting diode, has a very big advantage: No matter the vibration or impact will not easily damage the LED, and will not make it and the power plug disconnect. The two-pin design of the LED is used in highly vibrating products compared to the four-pin LED, which is more likely to break. Another advantage of the Eagle-Eye LED is its low thermal resistance. Because of its large lead frame design, most piranha type perforated LEDs are recognized as having the lowest thermal resistance. General LED and Eagle-Eye LED difference is shown in Table 2.

Table 1: Pin Description [4]

Pin No.	Pin Name	Function
1.	GND	Ground terminal for control logic and current sink
2.	R-EXT	Terminal used to connect an external resistor (R _{ext}) for setting up output current for all output channels
3.	QT	Set all the output current to 25% of the pre-set current when QT is low. Default value is high.
4,5.	OUT0~OUT1	Constant current output terminals
6.	ERR	Open drain thermal error flag, when junction temperature is over 165°C, ERR is going to low.
7.	OE	Output enable terminal. When OE is active (low), the output pins are enabled; when OE is inactive (high), all output pins are turned OFF (blanked).
8.	VDD	5V supply voltage terminal
-	Thermal Pad	Power dissipation terminals connected to GND

Table 2: General LED and Eagle-Eye LED Difference

LED Categories	General LED	Eagle-Eye LED
Pin Position	Two-pin	Four-pin
Power	20mA	30~100mA
Thermal Dissipation	Poor	Better
Beam type	Clustering type	Diffusion type
Lifetime Ratio	1	3

3.3 Relay

Also known as a courier, it is an electronic control device. It has a control system (also called input loop) and a controlled system (also called output loop). Usually used in automatic control circuits, it is actually an "automatic switch" that uses a smaller current to control a larger current. Therefore, it plays the role of automatic regulation, safety protection, and circuit conversion in the circuit. With the switching principle, the escape indicator circuit is operated in the energized state (power supply) and switched to operate the emergency lighting in the power failure state (power failure).

4. APPROVAL DIRECTIONS FOR EMERGENCY LIGHTING [5]

There are three note items of the approval directions for emergency lighting in Taiwan as follows:

1. Built-in battery type emergency power supply lighting time should be maintained for more than 1.5 hours (for the total number of emergency lights).
2. For the lighting 20 hours of temperature rise, shall not cause the luminaire departments discoloration, deterioration and other abnormalities occur, and shall not affect the characteristics and life of the light source.
3. The luminaire casing is made of synthetic resin and does not deteriorate or deform under normal use due to heat and light.

5. CIRCUIT DIAGRAM AND FINISHED PRODUCT

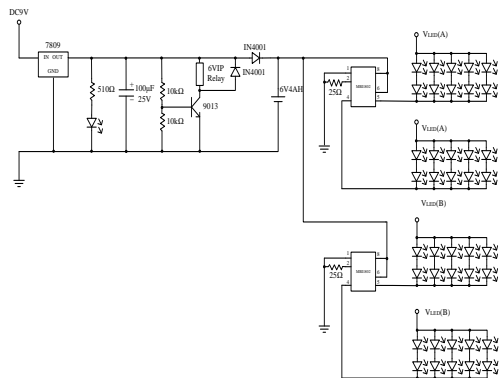

Figure 4: System Circuit Diagram



Figure 5: Physical Circuit Diagram

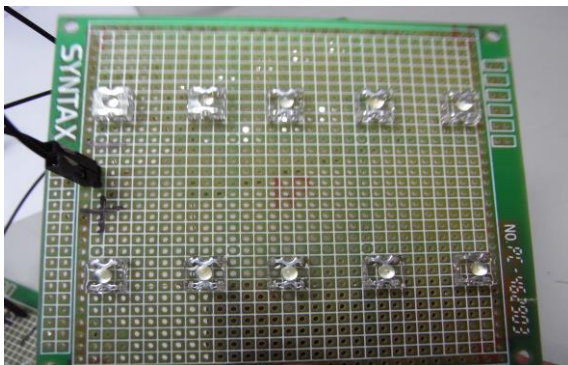

Figure 6: The Power Off State of The LED Board

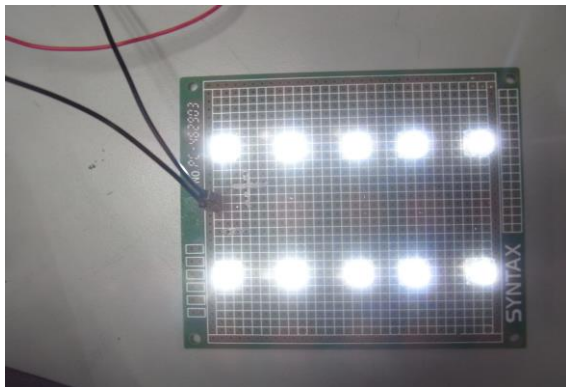

Figure 7: The Power ON State of The LED Board



Figure 8: The Finished Product in Power ON Period (Yellow Light)



Figure 9: The Finished Product in Power Off Period (White Light)

6. CONCLUSION and Future Research Development

Fig. 4 shows the system circuit diagram, Fig. 5 shows the physical circuit diagram, Fig. 6 shows the power off state of the LED board, Fig. 7 shows the power on state of the LED board, Fig. 8 shows the finished product in power on period (yellow light), and Fig. 9 shows the finished product with white light when the power is off. This paper can achieve the purpose of the LED indicator with emergency lighting function.

Its future research and development goals are: 1. reduce unnecessary impedance consumption. 2. try to use organic LED, LED (AC). 3. to achieve the approval directions for emergency lighting.

ACKNOWLEDGMENTS

The authors would like to acknowledge Mr. Jin-Kun Wu who constructed much of the hardware for the experimental system.

Conflict of Interest: None

Source of Funding: None

REFERENCES

1. Y. Y. Lu, *Practicum in Electronics* 4th edition, Gau-lih Books Ltd., 2008.
2. C.W. Lee, *Practicum Electronics*, TKDBOOKS Co., Ltd., 2008.
3. Mamoru Sato, *Introduction to Switching Power Supply Design*, Ken-shing Culture Co., 2008.
4. <https://www.neumueller.com/datenblatt/macroblick/MBI1802%20Ddatasheet%20VB.00-EN.pdf>
5. https://www.cfs.org.tw/f_doc/20150917115633.pdf

How to cite this article: Kao-Feng Yarn, Wen-Bin Lin. LED indicator with emergency lighting function. *International Journal of Research and Review*. 2022; 9(5):290-293. DOI: <https://doi.org/10.52403/ijrr.20220537>
