

The LED Warning Light by Photovoltaic Energy Charging

Wen-Bin Lin¹, Kao-Feng Yarn²

¹Department of Electronic and Optoelectronic Application Engineering, ²Department of Aircraft Maintenance, Far East University, Taiwan 744, ROC

Corresponding Author: Wen-Bin Lin

ABSTRACT

The pollution of the environment and demand for energy are more and more serious because of the speedy development in scientific technology. The new scientific technology of economizing energy and environmental protection is everyone's striving goal. Solid-state lighting source, such as MOCVD LED, is a light source component which accords with this goal. This paper presents an analogue photovoltaic warning lighting system. The proposed system consists of a photo voltaic module, phase control circuit, LED driving circuit, and a battery. In the paper, the types of photo voltaic module are introduced first. Then, implement a phase control circuit, an analogue controller and a switch circuit. In the sunny daytime, battery is charged by phase control circuit and during night supply to a LED lamp to achieve the capability of automatic warning lighting. Finally, an analogue controlled photovoltaic lighting system is implemented and to verify the theoretical analysis.

Keywords: Photo-voltage energy, light emitting diode, warning lighting, MOCVD LED

INTRODUCTION

Most vehicles use traditional warning triangle boards. Because it is a passive warning element, it will easily be undetected by other passing vehicles. However, if a high-brightness LED warning light is used, because it is an active warning element, it not only has a better warning function, but also achieves a more environment friendly and economical energy use.

The whole hardware composition is shown in Figure 1. The 18V photovoltaic panel or grid is charged to a 6V battery (The positive terminal of the battery is connected to Vcc, the negative terminal of the battery is connected to GND) through a regulated charging and phase control circuit (the grid and the photovoltaic panel are selected by a switch). The battery provides power to the LED driving and voltage detection circuit and (via the flicker circuit and the discharge circuit) high-brightness LED warning lights [1-12].

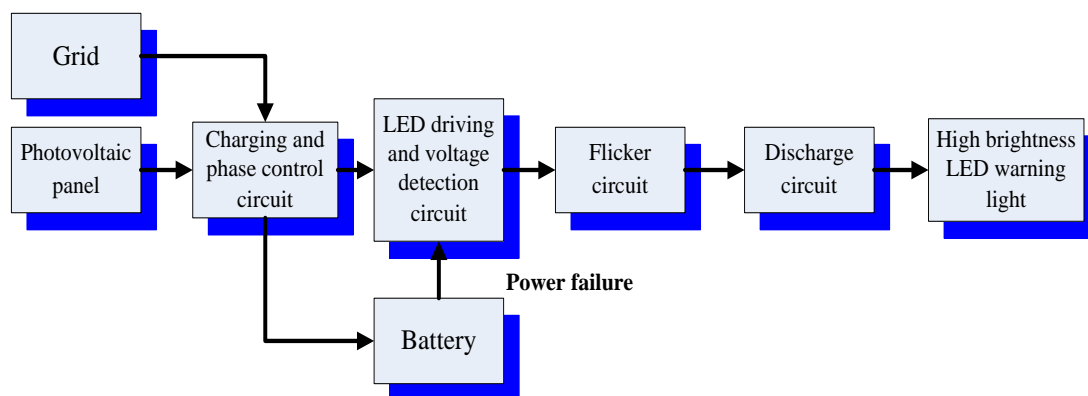

Figure 1: Block diagram of hardware composition

2. PRINCIPLE OF USING COMPONENTS

2.1 Phase Control Circuit and Charging Circuit Diagram [1,2]

In the implementation of this paper, as shown in Figure 2, it is the phase control circuit and the charging circuit. When the battery is exhausted, the battery voltage is lower than V_z , at this time SCR2 is cut off because its gate has no trigger signal, so the voltage rises. Therefore, the gate G of SCR1 gets a trigger voltage, SCR1 is turned on, and the current is charged to the battery 6V from the positive terminal of the power supply via SCR1.

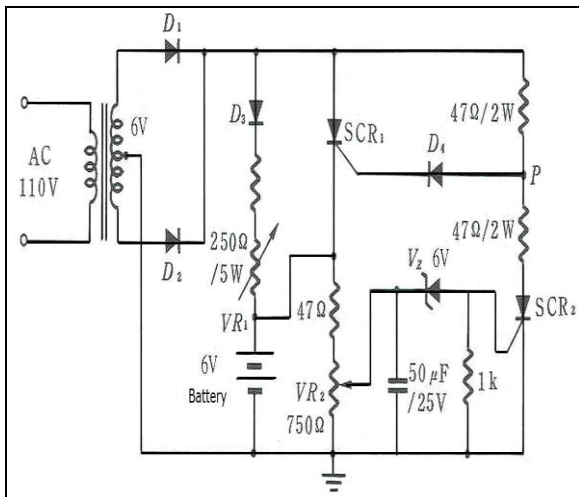

Figure 2: This implementation phase control circuit and charging circuit

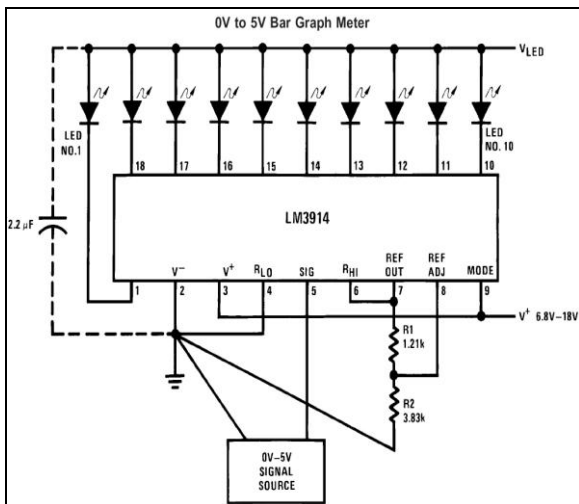

Figure 3: This implementation LED drive pin circuit [11]

2.2 LED Driver IC_LM3914 [11]

In the implementation of this paper, Figure 3 is the LM3914 used in the implementation. The biggest function of this

component is that it can activate all LEDs at the same time, which is usually called an LED driver IC. But this component has more than just these functions, which are fully explained in the figure below. In this implementation, we use LM3914 as an LED driver IC. Because it can make the brightness of the LED constant, and the LED can also have multi-functional changes, the brightness will be different because of the difference in resistance value. Therefore, the LED driver IC is selected.

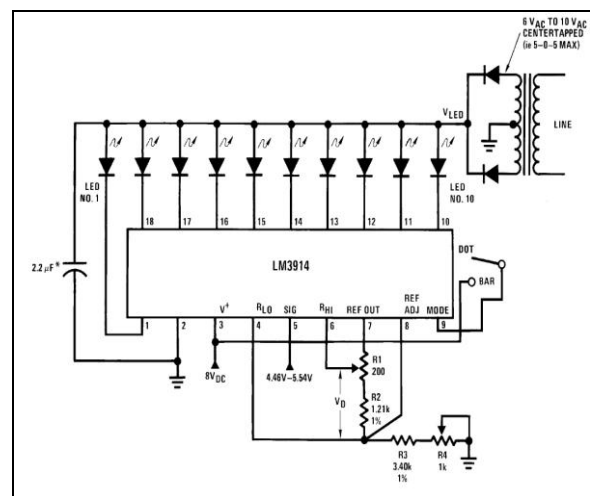

Figure 4: The implementation voltage detection pin circuit [11]

LM3914 can be used for voltage detection. The circuit in Figure 4 is an example. In this circuit, we can know that LM3914 can display different light signals according to different voltages (The lights we use are red, yellow, yellow, green and green). If the voltage is lower than the set voltage value, a light will be turned off. On the contrary, if the voltage is higher than the pin setting voltage, it will automatically carry to the next pin setting pin. Described as follows:

- (1) When the voltage turns from the highest point to the lowest point, the light number is as follows, green>green>yellow>yellow>red>red, the pin number: 18>17>15>14>12>11.
- (2) When the voltage is on from the lowest to the highest point, the light number is as follows, red>red>yellow>yellow>green>

green, and the pin number: 11>12>14>15>17>18 [11].

2.3 Flicker Circuit

As shown in Figure 5, a simple NPN transistor is used to perform the flicker function. Because a simple NPN transistor is added to the LM3914, we can get a pretty good flicker effect.

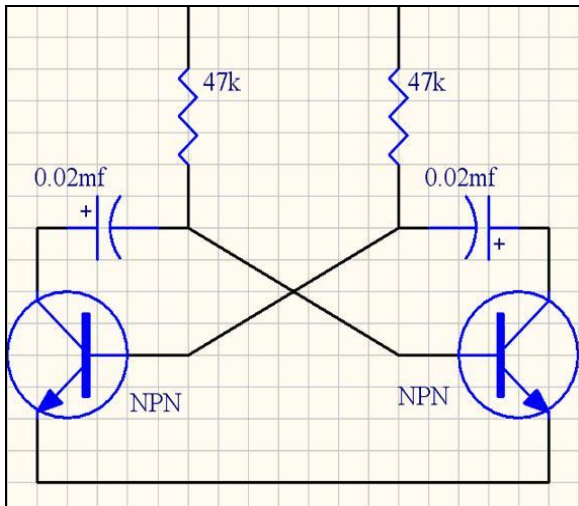

Figure 5: Flicker circuit in this implementation

2.4 Discharge Circuit

As shown in Figure 6, and in conjunction with Figure 2, when the battery is fully charged, because the battery voltage across is greater than V_z , the gate of SCR2 gets a trigger voltage and turns on. After SCR2 is turned on, the voltage drops, so there is no trigger voltage at the gate of SCR1, and the voltage at its anode drops to 0, and SCR1 is cut off.

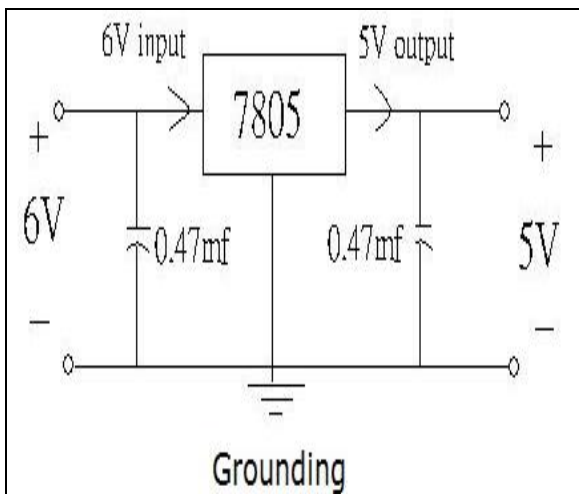

Figure 6: Discharge circuit in this implementation

2.5 Linear Voltage Regulator IC-7805

As shown in Figure 7, 78XX voltage regulator IC is a three-terminal element that can be used for voltage regulation. Now give 7812 parameters: 1 pin is input positive terminal, 2 pin is grounding, 3 pin is output positive terminal. The voltage regulation range is as follows: LM7805C is 5V, LM7812C is 12V, LM7815C is 15V [12].

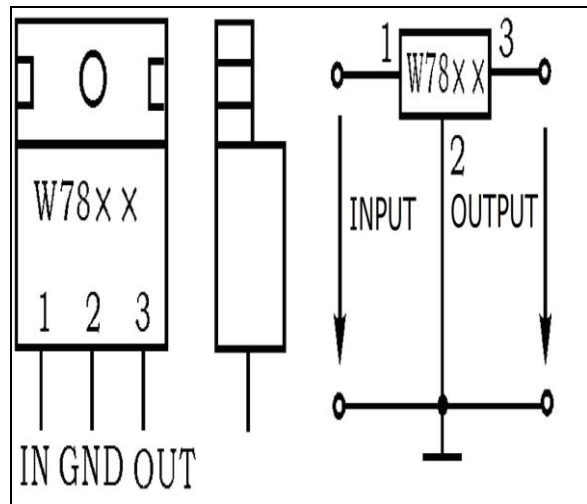

Figure 7: 7805 voltage regulator IC pin diagram

3. FINISHED PRODUCT

1. The system charges to the battery. It displays the current power with LM3914. It discharges (via switch). It steps down the voltage via 7805. It operates via LM3914.
2. Drive the charging circuit via photovoltaic panels or grid. Then through the switch to switch charging and perform actions to determine how to proceed. For example, when switching charging, the battery is charged through the charging circuit, and the current power in the battery is displayed through LM3914 (LED driver IC), so that the user can understand the current power.
3. Actions can be performed via a switch. The action of this circuit is to use a simple transistor to flicker. Then through the LM3914 to make all the LED drives for action, the LED flickers to achieve the warning function. The experimental data is shown in Table 1. The photos of the finished product are shown in Figure 8 to Figure 13.

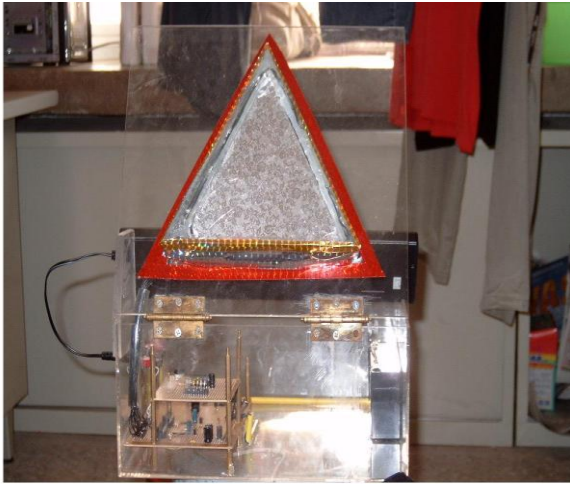

Figure 8: Implementation finished product (Front-view)



Figure 11: Implementation finished product (Side-view)

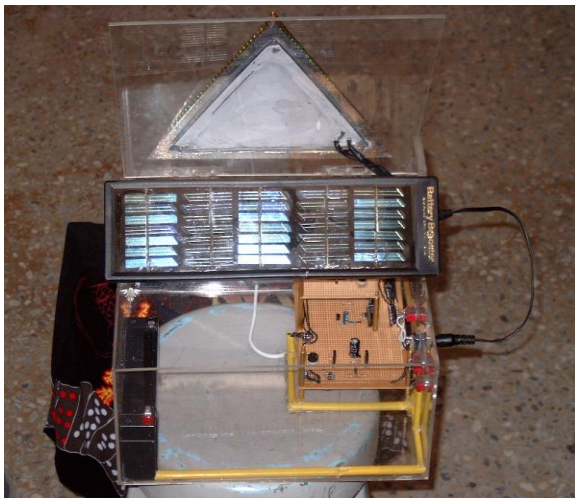

Figure 9: Implementation finished product (Rear-view)

CONCLUSION

The completed photos of the entities shown in Figure 8 to Figure 13.

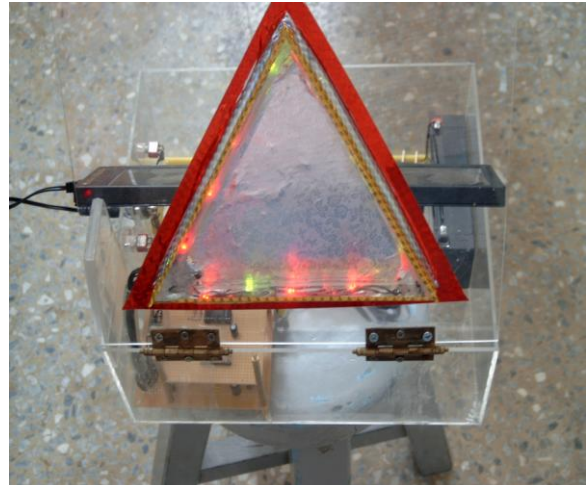

Figure 12: Implementation finished product (Fast flicker)

Table 1: Experimental data, the current value is 15mA (mA)

LED No.	1	2	3	4	5	6	7
Resistor (Ω)	220	200	200	190	190	190	185
Voltage(V)	3.3	3	3	2.85	2.85	2.85	2.77

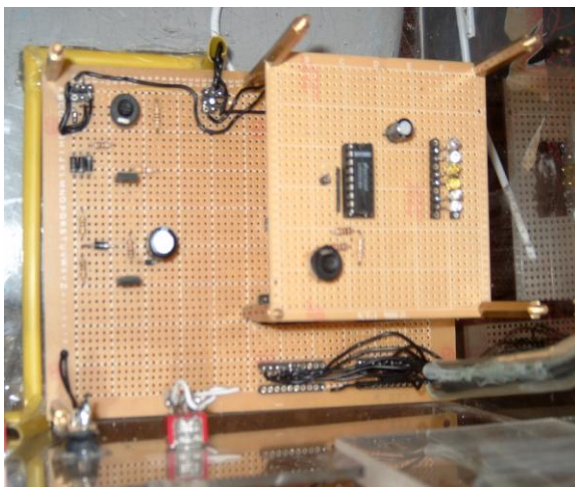

Figure 10: Implementation finished product (Internal circuit diagram)

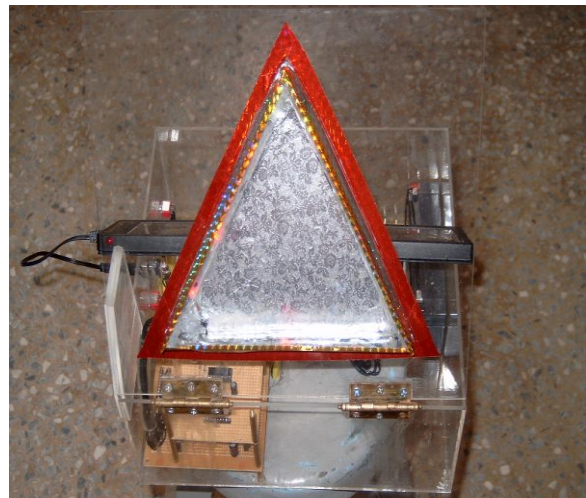

Figure 13: Implementation finished product (Slowly flicker)

In this paper, 18V solar panels or grid are charged to a 6V battery through a voltage regulator charging and phase control circuit (the grid and solar panels are selected by a switch). Since the number of analogue components and ICs is extremely small, the demand for component cost reduction is achieved. Finally, the feasibility of the system is verified through actual measurement.

The final charging effect, if the weather is good, the charging can be completed in about 12 hours.

ACKNOWLEDGMENTS

The authors would like to acknowledge Mr. Jin-Kun Wu who constructed much of the hardware for the experimental system.

REFERENCES

1. B. Y. Chen, Operational Amplifier Specification Table, Quanhua Science and Technology Book Co., Ltd., Taipei, Taiwan, 1983.
2. Q. X. Zheng, Sound Engineering, Quanhua Science and Technology Book Co., Ltd., Taipei, Taiwan, 1997.
3. LED-light emitting diode, <http://zh.wikipedia.org/wiki/LED>
4. Y. E. Wu, "Development of Solar Street Lighting System", 2010 9th Taiwan Power Electronics Conference and Exhibition, Vol.1, pp.231-pp.236, National Chung Cheng University, Chiayi, Taiwan, September, 2010 .
5. J. Gruetter, Using the latest generation of drivers to achieve high-brightness LED applications, Changhua, Taiwan, 2004.
6. Y. F. Chen, LED lighting market-LED lighting is highly anticipated, street lighting business opportunities are emerging, Taiwan, 2004.
7. E. Z. Han, LED lighting circuit, Taiwan, 2005.
8. Ella Chen, The characteristics and methods of high-power LEDs, Taiwan, 2005.
9. Y. H. Chiang, LED special lighting application and design discussion, Taiwan, 2005.
10. X. G. Chen , Implementing Green Lighting System with 5mm Ultra-high Brightness LED, Taiwan, 2005.
11. <http://cn.alldatasheet.com/datasheet-pdf/pdf/225418/NSC/LM3914.html>.
12. http://www.datasheetcatalog.com/datasheets_pdf/7/8/1/2/7805.shtml.

How to cite this article: Lin WB, Yarn KF. The LED warning light by photovoltaic energy charging. International Journal of Research and Review. 2020; 7(10): 115-119.
