

The Influences of Personal Resources on Employees' Affective Commitment

Abdirahman Mohamud Shire, Abdul Talib Bin Bon

Department of Technology Management, Faculty of Technology Management and Business, University Tun Hussein Onn Malaysia (UTHM) Parit Rajah, Batu Pahat, Johor, Malaysia.

Corresponding Author: Abdirahman Mohamud Shire

ABSTRACT

The aim of the paper is to identify and assess the relationships between personal and job resources with employees' affective commitment. The study was conducted on a sample that included 101 participants, selected from different Telecommunication companies. Personal and job resources, as variables, through their one-dimensional nature, were considered as independent variables, while affective commitment was recognized as dependent variables. Results have shown that personal and job resources have significant relationship with employees' affective commitment.

Keywords: Personal Resources; Job Resources; Affective Commitment; Telecommunication Companies

INTRODUCTION

There are three typical personal resources, namely, self-efficacy, organizational-based self-esteem, and optimism, ^[1] all of which have been recognized by ^[2] as fundamental components of individual adaptability. Self-efficacy refers to individuals' perceptions of their ability to meet demands in a broad array of contexts. ^[3] Accumulation of successes, as well as persistent positive experiences, augments general self-efficacy. ^[4] It has been shown that generalized and specific efficacy beliefs are correlated, and that the general tendency to feel efficacious may spill over into specific situations. ^[5] Organizational-based self-esteem (OBSE) is defined as the degree to which organizational members believe that they can satisfy their needs by participating in roles within the context of an organization". ^[6] Finally, optimism refers to the tendency to believe that one will generally experience good outcomes in life, ^[7] which increases

the propensity to take action and deal with threats. ^[1-7] In line with the core self-evaluations theory, ^[8] it is conceptualized these three personal resources as a unitary resiliency construct that plays a decisive role in employees' affective commitment.

Previous studies have shown that these personal resources are not only related to stress resilience, but also have positive effects on employees' affective commitment. ^[9-11] Although people's perception of and adaptation to environments is variable, depending on their levels of personal resources, these resource levels are cultivated by environmental factors. ^[9] Previous empirical studies have generally supported this triple role of the three personal resources. In relation to the role of personal resources and employees' affective commitment as are reciprocal, since individuals, through learning experiences, can form stronger positive evaluations about themselves and in turn, they comprehend or create more resourceful

work environments. Personal resources are positive self-evaluations that are linked to resiliency and refer to individuals' sense of their ability to control and impact upon their environment successfully. [10] It has been convincingly shown that such positive self-evaluations predict goal-setting, motivation, performance, job and life satisfaction, career ambition and other desirable outcomes such as high levels of affective commitment. [11] The reason for this is that the higher an individual's personal resources, the more positive the person's self-regard and the more goal self-concordance is expected to be experienced. [11] Individuals with goal self-concordance are intrinsically motivated to pursue their goals and as a result they trigger higher employees' affective commitment and then higher job performance and satisfaction. [12-13] Several authors have investigated the relationships between personal resources and employees' affective commitment. [13-15] For example, [14] found that committed employees use an active coping style. They are problem-focused, taking active steps to attempt to remove or rearrange stressors. Further, in their study among highly skilled employees, [15] examined the role of three personal resources (self-efficacy, organizational-based self-esteem, and optimism) in predicting employees' affective commitment. Results showed that engaged employees are highly self-efficacious; they believe they are able to meet the demands they face in a broad array of contexts. In addition, engaged workers have the tendency to believe that they will generally experience good outcomes in life (optimistic), and believe they can satisfy their needs by participating in roles within the organization (organizational-based self-esteem). These findings were replicated and expanded in a two-year follow-up study. [16] The findings indicated that self-efficacy, organizational-based self-esteem, and optimism make a unique contribution to explaining variance in employees' affective commitment over time, over and above the impact of job resources and previous levels

of employees' affective commitment. Therefore, The present study attempts to analyze how personal resources influence employees' affective commitment in Telecommunication Technology Sector.

LITERATURE REVIEW

Organisational Commitment

Organization commitment refers to the employee's emotional attachment to, identification with, and involvement in the organization. In essence, defining organizational commitment is an assessment of the congruence between an individual's own values and beliefs and those of the organization. [17] Organizational commitment is characterized as employees' willingness to contribute to organizational goals. When employees are sure that they will grow and learn with their current employers, their level of commitment to stay with that particular organization is higher. [18] In order to make employees satisfied and committed to their jobs, there is a need for strong and effective motivational strategies at various levels of the organization. Besides that, [19] have found a strong relationship between personal resources and organizational commitment. According to them personal resource is mostly determine how well the organization meets employees expectations.

Likewise, [19] believed that the organization concerned on the look after employees' interest. It is clear, the higher the personal resources, the more positive the impact on the commitment. Further, an individual's resources with their co-workers had the impact on highly commitment to the organization. [19] High level of organizational commitment provide a clear focus for human resource manager on the grounds that commitment is in itself good and positive that should lead to high level of work performance. [19]

The most prevalent approach to organizational commitment in the literature is one in which commitment is considered an affective or emotional attachment to the organization such that the strongly

committed individual identifies with, is involved in, and enjoys membership in, the organization. [18] This view was taken from [20] who described cohesion commitment as the attachment of an individual's fund of affectivity and emotion to the group and he also conceptualized commitment as partisan affective attachment to the goals and values of the organization, to one's role in relation to the goals and values, and to the organization for its own sake, apart from its purely instrumental worth. Similarly, the affective attachment approach is defined as the relative strength of an individual's identification with and involvement in a particular organization. [21]

Types of Employee Commitment

According, [21] several alternative models of commitment were proposed in the 1980s and early 1990s; multidimensionality was common to all. [22] There are three-component types of affective, continuance, and normative commitment. The most frequently used conceptualization of commitment is the three component model developed by. [22] This model has been subjected to empirical scrutiny and has arguably received the greatest support. [18-21] According to [20] Meyer & Allen defined organisational commitment as consisting of three separate concepts: affective, continuance, and normative commitment.

Affective commitment refers to feelings of belonging and a sense of attachment to the organisation. [22] Employees with high affective commitment will continue to stay in the organisation because they want to. Continuance commitment relates to perceived costs of leaving the organisation, including a perceived lack of alternatives. [20] Employees with strong continuance commitment will remain in the organisation because they feel they need to. Meanwhile, normative commitment manifests a feeling of obligation to remain with an organisation. [20] Employees with a high level of normative commitment feel that they ought to remain with the organisation. [22]

To date, the three-component conceptualisation of organisational commitment can be regarded as the dominant model in organisational commitment research. [20] However, the three-component of organisational commitment is not fully consistent with empirical findings. [23] Some scholars have argued that empirical inconsistencies derive from deeper rooted problems regarding the underlying concepts. [23] Empirical criticism of the three-component of organisational commitment has mainly revolved around two construct validity topics; that is, the position of continuance commitment as a dimension of the overall commitment construct, and the relation between normative and affective commitment. [24] Empirical dimensionality problems prompted Meyer and colleagues to revise and improve the instruments used for measuring continuance and normative commitment. [24] However, it seems that the underlying problem with these components is conceptual rather than empirical in nature. [25] Therefore, [26] proposed a return to the view that organisational commitment refers only to affective attachment. In addition, affective commitment represents the most reliable and strongly validated dimension of organisational commitment. [26] Social exchange theory also concluded that commitment is an affective state. [26] Among the three components of Meyer & Allen's theory, affective commitment exists as an important dimension of commitment toward their organisations. [25] Affective commitment is "positive feelings of identification with, attachment to, and involvement in, the work organisation". [25] It is one of the three forms of organisational commitment and denotes an emotional attachment to the organisation. Affective commitment was found to correlate most strongly with job performance. For example, in their work, [24] reported corrected correlations of affective commitment, normative, and continuance commitment with performance (0.16, 0.06, and -0.07) and OCB (0.32, 0.24, and -0.01).

Previous research also argued that strain is strongly related to affective commitment rather than to continuance and normative commitment. Consequently, the present study of this paper considered affective commitment to be the most relevant for the research purpose among the three types of organizational commitment.

Antecedents of Organizational Commitment

Building on [26]'s works on the antecedents of affective attachment to the organization, [22] maintained that these antecedents fall into four categories: personal characteristics, job characteristics, work experiences, and structural characteristics. Examples of personal and job characteristics are personal and job resources and job demands. The present study used three variables personal resources as antecedents of affective commitment. However, [27] also pointed out that affective component is strongly linked to work experiences especially "those experiences that fulfill employees' psychological needs to feel comfortable within the organization and competent in the work-role". Indeed, work experience has been widely accepted as the most determinant of affective commitment. [26]

For example, it was found that job resources was positively associated with affective commitment. [22] Job-related factors, such as job satisfaction [25] and job challenge. [26] improves affective commitment as well. Others studies showed positive relationships between organizational ethics. [28] human resource management practices. [25] and affective commitment. [29] found that higher perceived leader integrity is related to a higher level of affective commitment. Thus, most studies focus on aspects of work experiences and organizational characteristics as antecedents of affective commitment. However, the present focused personal characteristics as antecedents of affective commitment.

Relationship between Personal Resources and affective commitment

As mentioned before people with high proactive personality tend to be relatively unconstrained by situational forces and have a great effect on changing the environment. Additionally they identify opportunities and show initiative to create meaningful changes in their environment. [24] Those abilities have an influence on the variable of affective commitment, where employees identify with an organization, get involved in it, pursuing its goals and feel a strong bond towards it. [20] It could be assumed that if employees engage in opportunities to change their environments for personal and organizational benefits, it could influence their perceived attachment to the organization, because it would be a positive job and personal resources. As mentioned before, personal resource is a strong antecedent of affective commitment. This is why it is presumed that personal resources and affective commitment relate with each other.

Research Theoretical Framework

Figure 1 presents research framework, which explains the relationship between personal resources of employees' affective commitment.

Hypothesis

On the basis of the previous theoretical analysis, we hypothesized:

H1: Self-efficacy has a significant relationship with affective commitment.

H2: Organizational-based has a significant relationship with affective commitment.

H3: Optimism has a significant relationship with affective commitment.

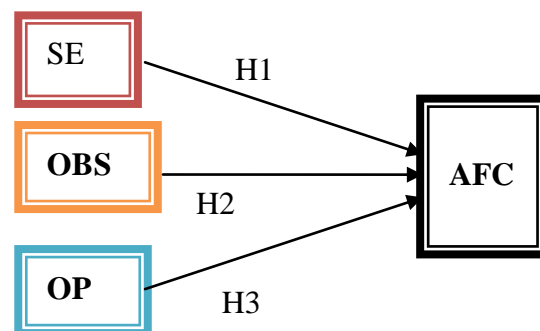

Figure 1: Research Framework

METHODOLOGY

Sample

Participants were full-time employees, obtained from a variety of telecommunication organizations. We contacted 101 employees. Nature of this research is quantitative. The research looks to evaluate the relationship between personal resources and employees' affective commitment.

Measures

The questionnaire for personal resources was developed by. [10] The employees' affective commitment scales are measured using the scale developed by. [20]

RESULT AND DISCUSSION

Structural Equation Modelling (SEM) is an advance statistical analysis method used to understand and analyze complex relationships between constructs in various disciplines, including social sciences. Furthermore, it has been used to evaluate more complex and sophisticated multivariate data, while multivariate analysis facilitates statistical investigation that simultaneously analyze multiple variables. [30] SmartPLS (version 3.0.M3) is suitable software and chosen to analyze and test this research data. Reliability refers to the "extent to which a variable or set of variables are consistent in what it is intended to measure". [30] To further investigate the reliability of the proposed constructs, Cronbach's Alpha and composite reliability measures were analysed and can be extracted from PLS-SEM. The measurements with Cronbach's Alpha and composite reliability above 0.70 are considered reliable and acceptable. [30] Compared to Cronbach's Alpha, Composite reliability is regarded as a more rigorous assessment of reliability. [30] The reliability level of the proposed constructs in this paper are documented in Table I. The results show that both Composite Reliability and Cronbach's Alpha values are above 0.90, consequently, the model realized an acceptable level of reliability.

Table I: Construct Reliability

Variable	Cronbach's Alpha	Composite Reliability
SE	0.922	0.969
OBS	0.967	0.987
OP	0.947	0.986
AFC	0.975	0.997

PLS-SEM is utilized because the structural model is an important instrument for assessing the significance level of the path coefficients between the variables. The analysis of the path coefficients was shown in Figure 2. The results have shown that there was significant positive relationship between two types of personal resources (Self-efficacy and Optimism) and employees affective commitment. Despite that there was positive relationship between Organizational-based and affective commitment, the relationship was not significant as shown in Table II.

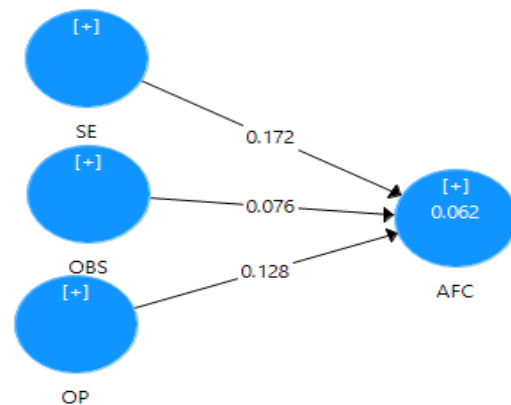

Figure 2: Structural model analysis

Table II: Bootstrapping Results

Dependent Variable	Independent Variable	Path Coefficient	T statistics	R ²
AFC	SE	0.172	2.560	0.062
	OBS	0.076	0.760	
	OP	0.128	1.998	

The present study attempted to assess the relationship between personal resources and employees' affective commitment. The findings showed high internal consistency for all of the instruments the researchers used in this study. The researchers used Cronbach alpha coefficients (α) as estimates of the reliability of all of the instruments they used in this study and found them acceptable compared to the guideline of $\alpha \geq 0.70$. [30]

The researchers used PLS-SEM to identify the relationship between the variables in the study. The study suggested that there is a relationship between three types of personal resources and affective commitment. The findings generally support the hypotheses.

The findings confirmed the first hypothesis of the study that there is a relationship between self-efficacy and affective organisational commitment. The findings show that affective organisational commitment has a positive relationship with self-efficacy. Previous studies, like that of, [15-20] confirm the finding that there is a positive relationship personal resources and affective commitment.

Likewise, the findings showed that second hypothesis which proposed that there is positive significant relationship between organizational-based and affective commitment, was partially supported as the relationship was positive but not significant.

Finally, the third hypothesis proposed that there is positive significant relationship between optimism and affective commitment, the findings have shown that there was a positive relationship between the two variables. Therefore, the overall objectives of the paper were achieved and mainly the previous studies supported the findings.

CONCLUSIONS

The aim of the study was to analyse the relationship between personal resources and employees' affective commitment. The adopted measures of this study have shown remarkable level of reliability as shown in Table I. Three hypotheses were developed. First and third hypotheses were fully supported, while second hypothesis was partially supported. Generally, based on the findings of the study, the personal resources have a significant relationship on employees' affective commitment.

REFERENCES

1. Airila A., Hakanen J. J., Schaufeli W. B., Luukkonen R., Punakallio A., Lusa S.

- (2014). Are job and personal resources associated with work ability 10 years later? The mediating role of work engagement. *Work Stress* 28, 87–105.
2. Anderson J. C., Gerbing D. W. (1988). Structural equation modeling in practice: a review and recommended two-step approach. *Psychol. Bull.* 103, 411–423.
3. Bakker A. B., Demerouti E., De Boer E., Schaufeli W. B. (2003). Job demands and job resources as predictors of absence duration and frequency. *J. Vocat. Behav.* 62, 341–356.
4. Bakker A. B., Demerouti E., Euwema M. C. (2005). Job resources buffer the impact of job demands on burnout. *J. Occup. Health Psychol.* 10, 170–180.
5. Brannick M. T. (1995). Critical comments on applying covariance structure modeling. *J. Organ. Behav.* 16, 201–213.
6. Cheung G. W., Rensvold R. B. (2002). Evaluating goodness-of-fit indexes for testing measurement invariance. *Struct. Equ. Model.* 9, 233–255.
7. Cole D. A., Ciesla J. A., Steiger J. H. (2007). The insidious effects of failing to include design-driven correlated residuals in latent-variable covariance structure analysis. *Psychol. Methods* 12, 381–398.
8. de Jonge J., Bosma H., Peter R., Siegrist J. (2000). Job strain, effort-reward imbalance and employee well-being: a large-scale cross-sectional study. *Soc. Sci. Med.* 50, 1317–1327.
9. Demerouti E., Bakker A. B., Nachreiner F., Schaufeli W. B. (2001). The job demands-resources model of burnout. *J. Appl. Psychol.* 86, 499–512.
10. Engel G. L. (1977). The need for a new medical model: a challenge for biomedicine. *Science* 196, 129–136.
11. Ensel W. M., Lin N. (2004). Physical fitness and the stress process. *J. Commun. Psychol.* 32, 81–101.
12. Freidl W. (1997). The impact of anomia as a factor in a demand resource model of health. *Soc. Sci. Med.* 44, 1357–1365. [PubMed]
13. Diener, E. (1984). Subjective well-being. *Psychological Bulletin*, 95, 542-575.
14. Gambetta, D. (Ed.). (1988). *Trust: Making and breaking cooperative relations*. New York: Basil Blackwell.
15. Graves, L.M., Ohlott, P., Ruderman, M.N.(2007). Commitment to family roles: Effects on managers' attitudes and

- performance. *Journal of Applied Psychology*, 92(1), 44-56.
15. Heller, D., Judge, T.A., Watson, D. (2002). The confounding role of personality and trait affectivity in the relationship between job and life satisfaction. *Journal of Organizational Behavior*, vol.23, issue 7, pages 815-835.
 16. Koohsar, A.A.H., Bonab, B.G. (2011). Relation between quality of attachment and life satisfaction in high school administrators. *Procedia - Social and Behavioral Sciences* 30 (2011) 954 – 958
 17. Koys, A.J. (2003). How the achievement of human resources goals drives restaurant performance, *Cornell Hotel and Restaurant Administration Quarterly*, 44, 17-24
 18. Landy, F. J., & Conte, J. M. (2010). *Work in the 21st Century: An Introduction to Industrial and Organizational Psychology* (Third Edition).
 19. Lawson K.J., Noblet A.J., Rodwell J.J. (2009). Promoting employee wellbeing: the relevance of work characteristics and organizational justice, 223-33.
 20. Martins, N. & Coetzee, M. 2007. Organizational culture, employee satisfaction, perceived leader emotional competency and personality type: An exploratory study in a South African engineering company, *South African Journal of Human Resource Management*, 5(2): 20-32.
 21. Segerstrom, S. C., Evans, D. R., Eisenlohr-Moul, T. A.(2011). Optimism and pessimism dimensions in the Life Orientation Test-Revised: Method and meaning. *Journal of Research in Personality*, 45, 126-129;
 22. Segerstrom, S. C.(2007). Optimism and resources: Effects on each other and on health over 10 years. *Journal of Research in Personality*, 41, 772-786;
 23. Bret Becton, J., Matthews, M., Hartley, D., & Whitaker, D. (2009). Using Biodata to Predict Turnover, Organizational Commitment, and Job Performance in Healthcare. *International Journal of Selection & Assessment*, 17(2), 189-202.
 24. Brimeyer, T., Perrucci, R., & Wadsworth, S. (2010). Age, Tenure, Resources for Control, and Organizational Commitment. *Social Science Quarterly* (Blackwell Publishing Limited), 91(2), 511-530.
 25. Daylo, Rodalyn E. Organizational Commitment of the Employees of the University of San Agustin (Unpublished Master's Thesis, University of San Agustin, 2008).
 26. Demir, C., Sahin, B., Teke, K., Ucar, M., & Kursun, O. (2009). Organizational Commitment of Military Physicians. *Military Medicine*, 174(9), 929-935. Retrieved from Academic Source Premier database.
 27. Espinosa, A.C. Factors Affecting the Organizational Commitment of Junior Officers in the U.S. Air Force, Retrieved on August 6, 2009 from <http://oai.dtic.mil/oai/oai?verb=getRecord&metadataPrefix=html&identifier=ADA145084>.
 28. Farzad, Atousa, (2006) The Effect of Internal Marketing on Organizational Commitment: An Investigation Among State-owned Banks in Isfahan, Iran. (Master's Thesis, Lulea University of Technology)
 29. Gemmiti, Marco, The relationship between Organizational Commitment, Organizational Citizenship Behavior Retrieved on August 6, 2009 from http://www.hausarbeiten.de/faecher/verschau/91123.html?partner_id=471166
 30. Air, J. F., Black, W. C., Babin, B. J., & Anderson, R. E. (2014). *Multivariate data analysis* (7th ed.). New York: Pearson Prentice Hall.

How to cite this article: Shire AM, Bin Bon AT. The influences of personal resources on employees' affective commitment. *International Journal of Research and Review*. 2017; 4(5):126-132.
